

Important Information About Your New Hunt Power Product

www.huntpower.com
hpinfo@huntpower.com

E-Mon D-Mon
A HUNT POWER PRODUCT

Hunt Power is committed to producing and delivering products of quality appearance and performance. That is why our meters are covered with a limited warranty against defects in workmanship and material. (See below for details.)

If you have questions, we can handle them quickly and effectively with a telephone call. Please let us try to help you by phone, BEFORE you remove your Hunt Power product. Call our technical department at (866) 944-4868 between the hours of 8:00 am and 7:30 pm, eastern time. To help us help you, please have all relevant information on hand when you call (model or part numbers, nature of difficulty, etc.).

Limited Warranty

Subject to the exclusions listed below, Hunt Power will either repair or replace (at its option) any product that it manufactures and which contains a defect in material or workmanship.

The following exclusions apply:

1. This Limited Warranty is only effective for a period of eighteen (18) months following the date of manufacture when installed in accordance with manufacturer's instructions by qualified personnel.
2. Hunt Power must be notified of the defect within ninety (90) days after the defect becomes apparent or known.
3. Buyer's remedies shall be limited to repair or replacement of the product or component which failed to conform to Hunt Power's express warranty set forth above.
4. Buyer shall be responsible for all freight costs and shall bear all risk of loss or damage to returned goods while in transit.
5. This Limited Warranty does not cover installation, removal, reinstallation, or labor costs, and excludes normal wear and tear. Buyer shall provide labor for the removal of the defective component or item and installation of its replacement at no charge to Hunt Power.
6. This Limited Warranty does not cover any product if: (i) a product is altered or modified from its original manufactured condition, (ii) any repairs, alterations or other work has been performed by Buyer or others on such item, other than work performed with Hunt Power's authorization and according to its approved procedures; (iii) the alleged defect is a result of abuse, misuse, improper maintenance, improper installation, accident or the negligence of any party; (iv) damaged as a result of events beyond Hunt Power's control or other force majeure events or (v) used in conjunction with equipment, components, accessories, parts or materials not supplied or approved by Hunt Power.
7. This Limited Warranty is limited to the obligation to repair and replace the manufactured product. This is the sole and exclusive remedy for breach of any warranty. THE TOTAL LIABILITY OF HUNT POWER, FROM ANY CAUSE WHATSOEVER, SHALL BE LIMITED TO THE PRICE PAID FOR THE PRODUCTS OUT OF WHICH SUCH CLAIM AROSE. IN NO EVENT SHALL HUNT POWER BE LIABLE FOR ANY INDIRECT, INCIDENTAL, SPECIAL, CONSEQUENTIAL OR PUNITIVE DAMAGES (INCLUDING ANY DAMAGE FOR LOST PROFITS) ARISING OUT OF OR IN CONNECTION WITH FURNISHING OF PRODUCTS, PARTS OR SERVICES, OR THE PERFORMANCE, USE OF, OR INABILITY TO USE ANY PRODUCTS, PARTS OR SERVICES, SALE OF OR OTHERWISE, WHETHER BASED IN CONTRACT, WARRANTY, TORT, INCLUDING WITHOUT LIMITATION, NEGLIGENCE, OR ANY OTHER LEGAL OR EQUITABLE THEORY.
8. EXCEPT AS EXPRESSLY PROVIDED HEREIN, HUNT POWER MAKES NO WARRANTY OF ANY KIND, EXPRESSED OR IMPLIED WITH RESPECT TO ANY PRODUCTS, PARTS OR SERVICES PROVIDED BY HUNT POWER INCLUDING, BUT NOT LIMITED TO, THE IMPLIED WARRANTIES OF MERCHANTABILITY AND FITNESS FOR A PARTICULAR PURPOSE. PRODUCTS OR COMPONENTS DISTRIBUTED, BUT NOT MANUFACTURED, BY HUNT POWER ARE NOT WARRANTED BY HUNT POWER AND BUYER MUST INSTEAD RELY ON THE REPRESENTATIONS AND WARRANTIES, IF ANY, PROVIDED DIRECTLY TO THE BUYER BY THE MANUFACTURER OF SUCH PRODUCT OR COMPONENT.

Class 3000 Advanced kWh/Demand Meter With Communications

Installation & Instruction Manual



Dear Valued Customer,

We are pleased that you chose to buy one of our products and want you to be just as pleased with it. To be sure that you are 100% satisfied with our products, we provide toll-free technical and sales support Monday through Friday, 8:00 am to 7:30 pm, eastern time, (866) 944-4868. You may also reach us via email at hpinfo@huntpower.com.

Before installing your new Hunt Power product, please read the information on the following pages carefully.

Be sure to forward this manual to the owner after installation is complete so that they may use it as a reference guide when reading the E-Mon D-Mon® meters.

Thank you.



Technical Specifications

Ordering Information:	Simply state voltage, current rating and any options required: EXAMPLE: Voltage _____ 208 200 C M = Model No. Current Rating _____ 208200CM Communications _____ Modem Option _____
Voltage Input Configuration:	3-wire and 4-wire
Voltage Input:	Up to 480 volts rms AC available
Current Input:	Up to 3200 amps rms AC available
Power Factor:	0.5 leading or lagging
Frequency:	50-60 Hz
Accuracy:	Certified to ANSI C12.16 (+/-1% from 1%-100% of rated load).
Voltage Operating Range:	+/- 25% of rated load
Temperature Range:	-20 degrees C to +50 degrees C
Voltage Overload:	+25% continuously
Current Overload:	Can be overloaded 100% without damaging meter
Display:	kWh, Peak kW, kW Load, Amps per Phase, Volts per Phase and Power Factor per Phase
Standard Ranges:	120/208 volts; 100, 200, 400, 800, 1600, or 3200 amps 277/480 volts; 100, 200, 400, 800, 1600, or 3200 amps

Chapter 1	Pre-Installation Information	Page 2
Chapter 2	Current Sensor Assembly	Page 5
Chapter 3	Main Power Board Connections <i>Current Sensor Connections</i> <i>Voltage Connections</i>	Page 6 <i>Page 6</i> <i>Page 6</i>
Chapter 4	Meter Terminal Block Connections	Page 7
Chapter 5	Installing the Class 3000 Meter	Page 10
Chapter 6	Wiring Diagrams	Page 11
Chapter 7	Monitoring Multiple Loads with One Meter	Page 12
Chapter 8	Reading the Class 3000 Display	Page 14
Chapter 9	Class 3000 Features	Page 15
Chapter 10	Module Diagnostics <i>Line Voltage Diagnostics</i> <i>Current Sensor Diagnostics</i> <i>Other Diagnostic Messages</i>	Page 18 <i>Page 18</i> <i>Page 18</i> <i>Page 22</i>
Chapter 11	Frequently Asked Questions	Page 23
Appendix A	RS-485 Communications	Page 24
Appendix B	RS-232 Communications	Page 26
Appendix C	Modem Communications	Page 29
Appendix D	ModBus Communications	Page 32
Appendix E	Ethernet Communications	Page 35

Chapter 1 Pre-Installation Information

The Class 3000 meter is a three-element meter with communications. This device is used to monitor electric power usage of individual loads after the utility meter and to store data for automatic meter reading. Installation should be performed by qualified personnel ONLY according to these instructions and in accordance with local electrical codes. Hunt Power and its representatives assume no responsibility for damage or injury resulting from the improper installation of this meter.

Verify the rating and configuration on the meter label to ensure it is suitable for the intended service. Class 3000 meters listed for use on 120/208 volt services CANNOT be used on 277/480 volt services, and vice versa.

Verify that the meter's current sensors are suitable for the intended load. Compare the color of the arrows on the sensor to the chart below.

Sensor Arrow Color Code		Sensor Rating
Brown	-	100 Amp
Red	-	200 Amp
Yellow	-	400 Amp
Black	-	800 Amp
Blue	-	1600 Amp
(2) Blue	-	3200 Amp

Precautions should be observed when handling this meter as electronic circuitry can be damaged by electrostatic discharge (ESD). Be extremely careful not to touch the internal circuits prior to discharging any static buildup on your person. To discharge yourself, touch something that is grounded, such as a conduit or a grounded metal enclosure.

Note: Class 3000 meters must be installed indoors, where they will not be affected by the elements.

Appendix E Ethernet Communications

Class 3000 Ethernet/IP-addressable meters can be tied into a local Ethernet network individually, or a single Ethernet-connected meter can communicate with multiple RS-485 daisy-chained conventional Class 3000 meters using a single IP address. Refer to the diagram shown below.

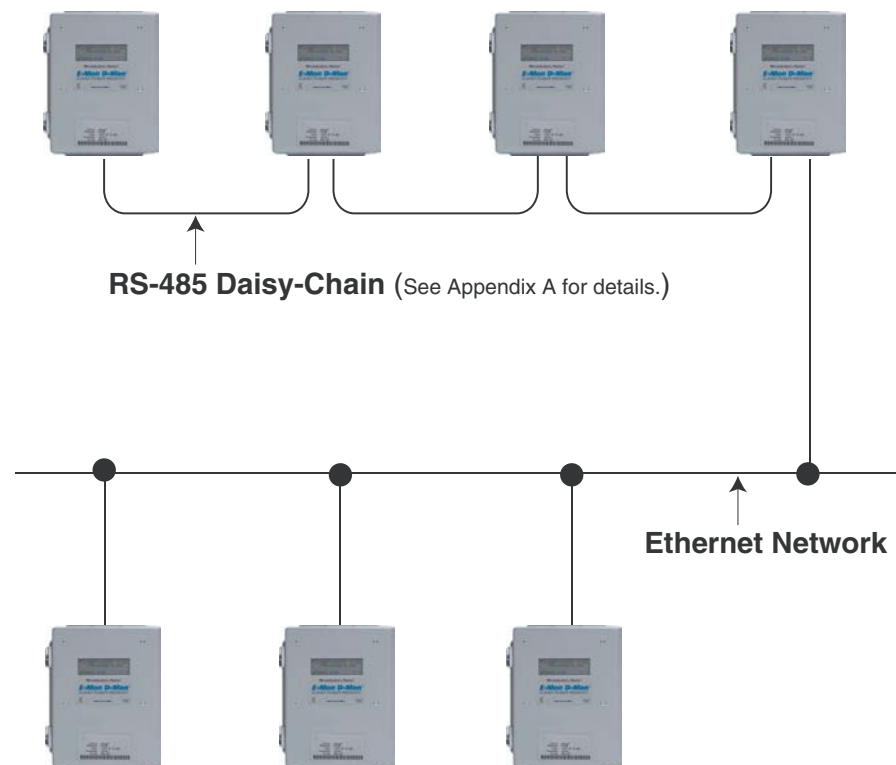

Appendix D ModBus Communications

ModBus Point Map

The point map below shows the location of the data that can be accessed with ModBus protocol. Instructions for changing the ID number and date/time are also shown on the point map.

E-Mon D-Mon Modbus Point Map										1.02	11/06/03	s:\my documents\excel\emondmon-modbus-pointmap-f10x.xls
ITEM	PM-I	W	PM-F	UOM	CALC.	MEM	OP	DESCRIPTION	Promon 2K	MS 5000		
1	40001	2	41001	kWh	T-del	NV	R/W	Energy delivered	Y	Y		
2	40003	2	41003	kWh	T-rec	NV	R/W	Energy received	Y	Y		
3	40005	2	41005	kVARh	T-del	NV	R/W	Reactive energy delivered	Y	Y		
4	40007	2	41007	kVARh	T-rec	NV	R/W	Reactive energy received	Y	Y		
5			41009	kW	T		R	Real power	Y	Y		
6			41011	kVAR	T		R	Reactive power	Y	Y		
7			41013	kVA	T		R	Apparent power	Y	Y		
8			41015	%	T		R	Power factor	Y	Y		
9			41017	Amps	T		R	Current total	Y	Y		
10			41019	Amps	A		R	Current average	Y	Y		
11			41021	Volts-N	A		R	Voltage line-neutral	Y	Y		
12			41023	Volts-L	A		R	Voltage line-line	Y	Y		
13			41025	Hz	A		R	Frequency	Y	Y		
14			41027	Degree	A		R	Phase angle	Y	Y		
15			41029	kW	ØA		R	Real power, phase A	Y	Y		
16			41031	kW	ØB		R	Real power, phase B	Y	Y		
17			41033	kW	ØC		R	Real power, phase C	Y	Y		
18			41035	kVAR	ØA		R	Reactive power, phase A	Y	Y		
19			41037	kVAR	ØB		R	Reactive power, phase B	Y	Y		
20			41039	kVAR	ØC		R	Reactive power, phase C	Y	Y		
21			41041	kVA	ØA		R	Apparent power, phase A	Y	Y		
22			41043	kVA	ØB		R	Apparent power, phase B	Y	Y		
23			41045	kVA	ØC		R	Apparent power, phase C	Y	Y		
24			41047	% PF	ØA		R	Power factor, phase A	Y	Y		
25			41049	% PF	ØB		R	Power factor, phase B	Y	Y		
26			41051	% PF	ØC		R	Power factor, phase C	Y	Y		
27			41053	Amps	ØA		R	Current, phase A	Y	Y		
28			41055	Amps	ØB		R	Current, phase B	Y	Y		
29			41057	Amps	ØC		R	Current, phase C	Y	Y		
30			41059	Volts-N	ØA		R	Voltage, line to neutral, phase A-N	Y	Y		
31			41061	Volts-N	ØB		R	Voltage, line to neutral, phase B-N	Y	Y		
32			41063	Volts-N	ØC		R	Voltage, line to neutral, phase C-N	Y	Y		
33			41065	Volts-L	ØA		R	Voltage, line to line, phase A-B	Y	Y		
34			41067	Volts-L	ØB		R	Voltage, line to line, phase B-C	Y	Y		
35			41069	Volts-L	ØC		R	Voltage, line to line, phase C-A	Y	Y		
36			41071	Degree	ØA		R	Phase angle, phase A	Y	Y		
37			41073	Degree	ØB		R	Phase angle, phase B	Y	Y		
38			41075	Degree	ØC		R	Phase angle, phase C	Y	Y		
ITEM	PM-I	W	DATA (SAMPLE)				DESCRIPTION					
46001	8		504D 324B 0102 1016 0300 454D 4F4E 2020	Firmware version: PM 5K, Ver, Ver date/time, EMON				R				
46009	8		456E 6572 6779 204D 6574 6572 0000 0000	Device description: Emon Energy Meter				R				
46017	8		1356 4503 0613 0300 0000 0000 0000 0000	Initialize device with date/time				W				
46025	8		1356 4503 0613 0300 0000 0000 0000 0000	RTC date/time, will accept broadcast command				R/W				
46033	8		1356 4503 0527 0300 0000 0000 0000 0000	CPU date/time (7 bytes, rest is reserved for other future formats)				R/W				
46041	8		0001 0001 0000 0000 0000 0311 0020 1100	Group, location, Device ID number				R/W				
46049	8		0041 0000 0000 0000 0000 0311 0020 1100	Dev. ID, Hookup, Serial numbers....				R/W				
46057	8		0592 0007 0000 0000 0000 0000 0000 0000	Recorder info.: idr, dem, int., dem, win., dem, syn., timezone, DST...				R/W				
46065	8		0101 0001 0D03 3531 1000 0320 0000 0000	Meter info.: SN1&2, pulse rate, Volt/Amp/CTs, PF/mult1&2, CT, PT				R/W				
46513	8		0000 0101 0000 0000 0000 0100 0000 0000	Flags L1								
46521	8		0000 0000 0000 0000 0000 0000 0613 0316	Flags L2								
46529	8		0000 0000 0000 0000 0000 0000 0000 0000	Flags L3								
46537	8		0000 0000 0000 0000 0000 0000 0000 0000	Flags L4								

Note: To change device ID, set single point at 46049 with data set to new device ID (e.g. 1 to 247)
 To set date/time, set multiple points at 46025 for 4 points with data set to HHMM SDDW MMDD YYYY (DW=day of week)
 To clear single meter kWh/kW, set single point at 41001 with data set to 0000 (similarly for 41003, 41005, 41007)
 To clear multiple meter readings, set multiple point at 41001 for 8 points with data set to 0000's
 Note: Jumper J5 & J6 must be closed in order for kWh del/rec and kVARh del/rec to be cleared

Chapter 1 Pre-Installation Information

Internal Electronic Assemblies

The Class 3000 meter has 2 *standard* circuit assemblies: the main power board and the CPU board, which are joined together by a flat ribbon cable.

Main Power Board

This circuit board is located inside the enclosure. The meter's main power input transformer is mounted on the left side of this circuit board. A clear plastic protective shield covers the main power board. **All connections needed to make the Class 3000 meter operational are on this board.**

CPU Board

The CPU circuit board is located on the top of the inside of the door. **The only connection that is required to this board is for RS-485/ModBus communications.**

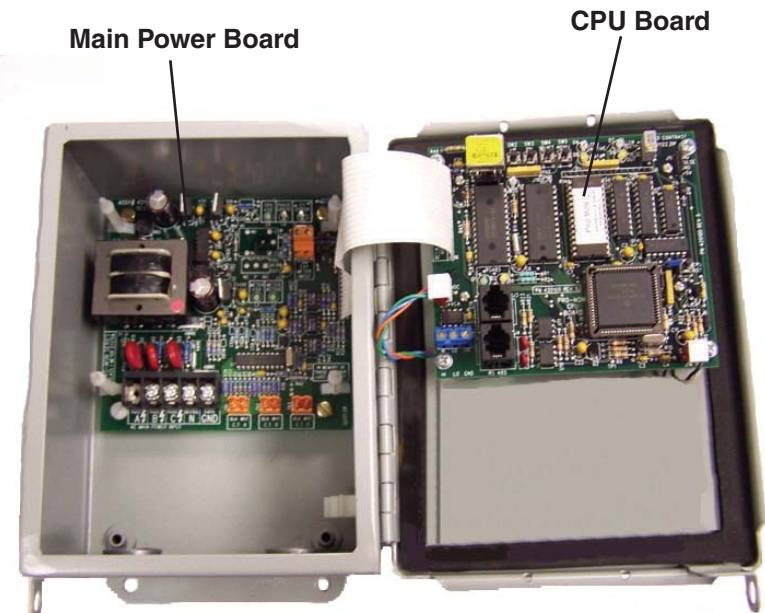

Class 3000 Meter Setup Screen

On the CPU board, locate the small pushbutton SW1 near the right center of the board. This is the *CPU Reset* button. Using the blunt end of a pen or other thin plastic tool, press this button while watching the display. The meter will display its setup screen for a few seconds then return to normal mode. The setup screen display will show “MD” (upper left) as well as the meter’s configurations. For example:

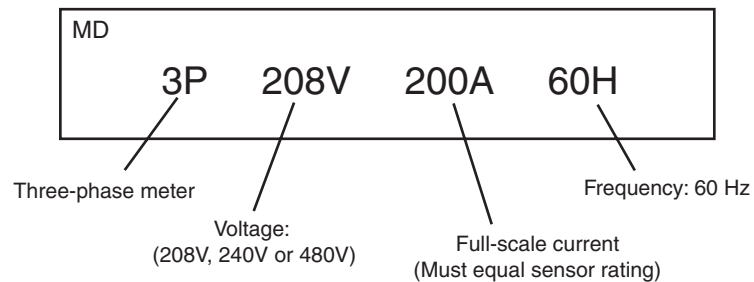

If the displayed voltage DOES NOT MATCH the meter's label, contact Hunt Power's technical support department at (866) 944-4868 before continuing.

The meter's full-scale current on the display should match the current rating stamped on the front of the meter.

Current Sensors

The Class 3000 meter can be used with two basic types of current sensors:

1. Split-core current sensors - These sensors open so that they can be attached around the circuits being monitored without interrupting power.
*Unless otherwise specified, Class 3000 meters are supplied with this type of sensor.

2. Solid-core current sensors - Do not open. The conductor being monitored must be passed through the opening in the appropriate sensor.
*Optional; specify when ordering.

The current sensors MUST have the same current rating as the meter.

Important: The label on the front panel indicates if the meter is set up to use split-core or solid-core sensors.

Installation Overview

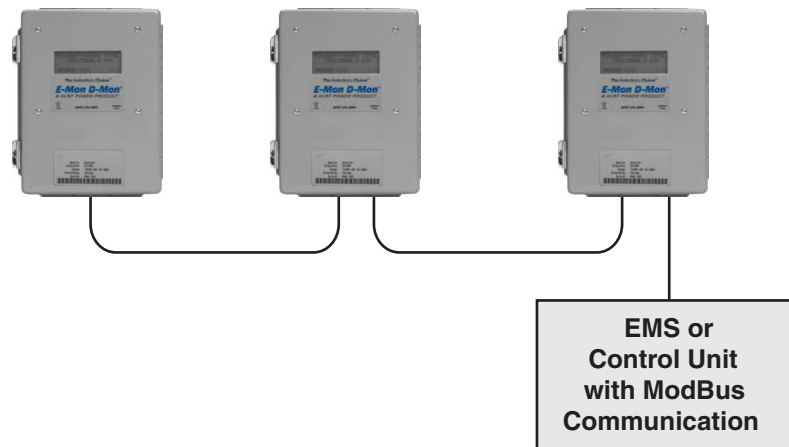

Appendix D ModBus Communications

The Class 3000 ModBus meter communicates with building automation equipment over a 2-wire (3-conductor) RS-485 network using ModBus RTU protocol.

The meters are networked in a daisy-chain configuration (Appendix A) with BELDEN 1120A cable or equivalent. The cable rating of 600V allows the RS-485 network to be connected to 480-volt meters. Up to 64 meters can be installed on a network string. The maximum combined length of all daisy-chained cables must not exceed 4000 feet. The meter-to-network connection is through the 3-screw terminal which is located on the CPU board, on the door of the meter. The pictures below show the terminal location and correct wiring method for ModBus communication.

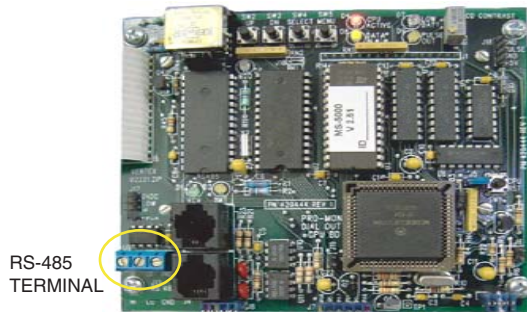

Wiring Details

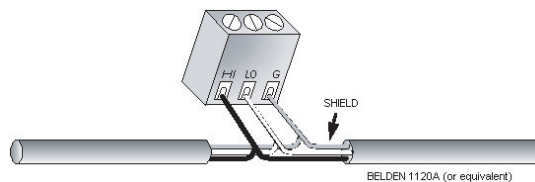

The meter is shipped with a ModBus ID number of 01. This must be changed if the network has more than one meter installed. The change must be done before the meter is introduced into the network. The meter can be numbered from 1 to 247. There can be no duplicate numbers on a network, so caution must be taken when assigning a meter ID number prior to its installation on the RS-485 network.

Chapter 2 Current Sensor Assembly

STEP 1:

For each phase being monitored you will need one two-piece current sensor assembly. (A three-phase meter will require three (3) assemblies.) Open the two-piece current sensor assembly by releasing the nylon clamp using a flathead screwdriver.



STEP 2:

Reassemble current sensor assembly around the conductor(s) to be monitored. Be sure that the current sensor halves marked "load" are both facing the load side of the conductor. The colored arrow will be on the source side of the conductor being monitored and **MUST** be pointed in a clockwise direction around the conductor being monitored. Tighten nylon clamp to complete assembly.

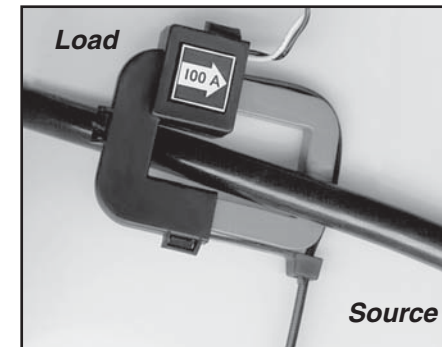

IMPORTANT: When looking from the source side of the conductor(s) being monitored, you should see the arrow on the current sensor assembly, and the arrow should be pointing clockwise around the conductor(s) being monitored.

If the arrow is not on the source side, inaccurate readings will result.

Chapter 3 Main Power Board Connections

AC Main Power Input Terminals (J1):

This main board has a large black terminal block (J1) located on the bottom left corner of the main power board for connecting the line voltage. This 5-position terminal block will accept the bare end of stranded or solid wires up to 12 gauge.

Current Sensor Inputs (TB1, TB2 and TB3):

There are three removable orange connectors for the current sensor inputs located on the bottom right corner of the main power board.

- TB1 = Phase A current sensor input
- TB2 = Phase B current sensor input
- TB3 = Phase C current sensor input

External Meter Input (TB4):

This input is located on the top right corner of the main power board. This input is used for an external utility meter or submeter input being monitored by the Class 3000 meter. The data is accessed only through Hunt Power's RightEnergy™ software, and is not shown on the meter display.

There are 3 registers on the Class 3000 meter. Register 1 is for kWh, Register 2 is for kVARh and Register 3 contains the pulse data from the external input TB4. This data is determined by the type of meter supplying the pulse (water, gas, etc.). Registers 1 & 2 are from the meter and are always functioning.

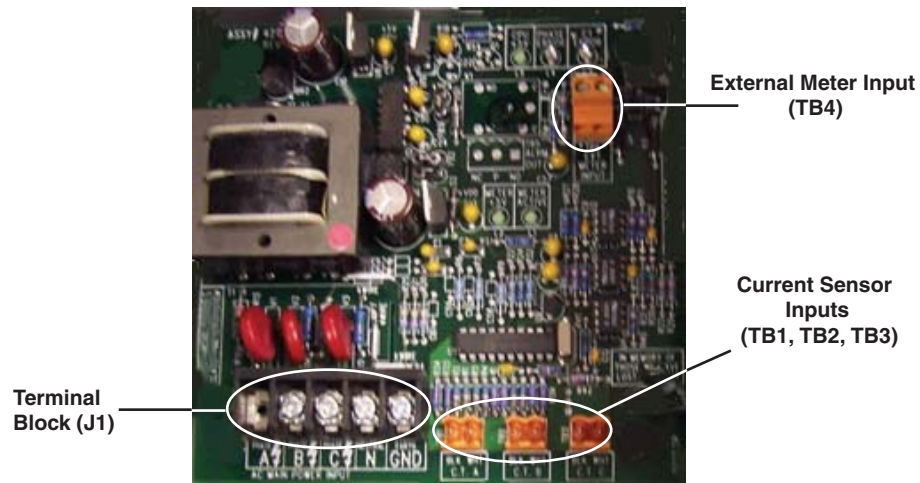

Appendix C Modem Communications

Configuration Diagram

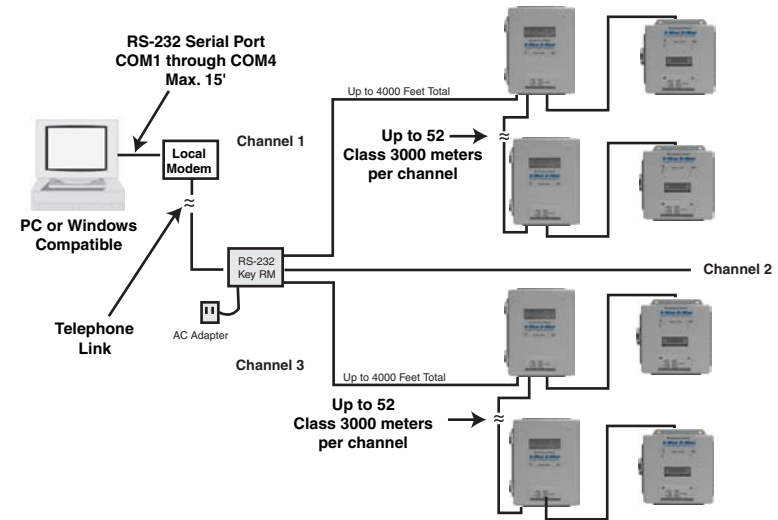

Appendix C Modem Communications

B. Using the RS-232 Key with an External Modem (continued)

4. Connect the RS-232 Key 2000 to the external modem using the supplied 8-conductor flat modular cable.
5. Connect the 7VAC adapter to the power input on the back of the RS-232 Key and plug it into a 120VAC outlet.

Important: The modem should use a phone line that is dedicated exclusively to the AMR system. Do not use a phone line that is shared by another modem or fax machine.

C. Baud Rate Selection

The communication baud rate is selected by means of a jumper on the circuit board. There are three (3) selections: 19200, 9600 and 2400. The default selection, as shipped from the factory, is 9600.

1. When using the Class 3000 meter with a modem, the rate of 9600 should always be selected.
2. The baud rate on the meter must always match the baud rate selected in the RightEnergy™ software. Communications will not work if they are not set correctly.
3. After a baud rate change, press *CPU Reset* to register the change.
4. All meters in the daisy-chain circuit must be set at the same baud rate.

Chapter 4 Meter Terminal Block Connections

Connect three-phase AC power to the 5-position terminal block (J1) located at the bottom left corner of the main power board. (Refer to the picture on the previous page.) These terminals are clearly labeled PHASE A, PHASE B, PHASE C, NEUTRAL, EARTH-GROUND.

- STEP 1: Connect the neutral wire to the terminal block. On a 3-wire delta-type meter, the neutral terminal is not used.
- STEP 2: Connect the three AC main power wires (phases A, B and C).
- STEP 3: Turn ON the AC main power input. The meter display will light up and scroll through 6 displays. Each display is visible for 10 seconds.
DISPLAY SCREENS are as follows:
Screen 1 - Total kilowatt-hours (kWh) consumed
Screen 2 - Peak demand (kW) with date & time stamp
Screen 3 - Actual load (kW) with preset date & time
Screen 4 - Average current (amps) per phase
Screen 5 - Average voltage (volts) per phase
Screen 6 - Power factor (PF) per phase
- STEP 4: Verify the voltage readings on Screen 5. Typical readings on each phase with respect to neutral are shown below. Readings should be +/-10% range.

Meter Type	Nominal Voltage	+/-10% Range
208/240V, 3 Ph, 4W	120VAC	108 to 132 VAC
480V, 3 Ph, 4 W	277VAC	249 to 305 VAC
208/240 V, 3 Ph, 3W	240VAC	216 to 264 VAC
480V, 3 Ph, 3W	480VAC	432 to 528 VAC

Note: If you see the messages "Check Meter" or "Low Battery" on the display, refer to Chapter 10, *Module Diagnostics*.

Note: Meters are powered by phases A and B. The displayed voltages will be the measured AC voltage between phases.

Chapter 4

Meter Terminal Block Connections

Phasing of Line Voltage

The 3-phase AC power input must be in proper phase sequence. If the sequence is incorrect, there will be a message on the meter's display: *PHASE [2]. If Phase B and/or Phase C are missing, there will be a message on the meter's display: *PHASE [3]. (Refer to Chapter 10, *Module Diagnostics*, if either of these messages are present.) When the line voltage is connected correctly the meter's display will be blank (no message).

A red LED on the main power board turns on if a line phase error is detected. This LED is labeled PHASE ERROR and is located on the top of the main power board.

Wait for the meter display to scroll to the voltage display. Verify that the meter reads correct voltages on all three phases. Repeat Step 4 (previous page).

Once the meter displays the correct line voltages and there are no error messages you are ready to connect the current sensors to the meter.

Before continuing with the installation, verify the six screens display as follows:

- Screen 1 (*kWh*): Should read 0.0 kWh; if not, should be reset.
- Screen 2 (*kW Peak Demand*): KW Peak should read 0.0 kW. There will not be a date/time stamp yet. If there is a kW peak recorded, it should be reset later. (See Chapter 9.)
- Screen 3 (*Load/Clock Calendar*): Should read 0.0 kW load. The present date and time are shown. If the clock calendar reading is not correct, it should be set correctly later. The time-of-day clock should be running.
- Screen 4 (*Amps per Phase*): There should be 0.0 on all three phases.
- Screen 5 (*Average AC Volts*): See the chart shown in Step 4 (previous page).
- Screen 6 (*Power Factor*): There should be 0.0 PF on all three phases.

Note: The meter will be reset later via the software during "startup" procedures. Resetting the kWh reading and clock calendar must be done at the host computer via the RS-485 communications link or modem.

Appendix C

Modem Communications

A. RS-232 Key with Built-In Modem (RS-232 KEY RM)

The RS-232 Key with built-in modem connects the entire RS-485 network of Pro-Mon[®]s to a telephone line.

** Refer to Appendix B (*RS-232 Communications*). Connect the RS-485 network via Method 1 or Method 2.

On the back panel of the RS-232 Key/modem, the left jack (*RS232*) is not used in most cases since there is no local host computer.

The two jacks at the top center of the rear panel on the RS-232 Key/modem are for connecting to the phone line. Connect one of these two jacks to the telephone line.

Important: The telephone line should be dedicated exclusively to the automatic meter reading system. Never connect to a phone line that has other modems or fax machines connected. If there are telephones connected to this phone line, the proprietor must be aware that all phones must be on "hook" in order for the modem to work. A dedicated telephone line is suggested for system reliability.

B. Using the RS-232 Key with an External Modem

1. All meters should be connected to the RS-232 Key as described above.
2. DISCONNECT POWER TO THE RS-232 KEY. Remove the cover by removing the 2 screws from the bottom of the enclosure.
3. On the circuit board, locate the blue jumpers J7 (MODEM) and J8 (ex-MODEM). If these jumpers are set in the DIRECT position, you must move the jumpers so they are set in the MODEM position. Replace the cover and secure the enclosure.

Configuration Diagram

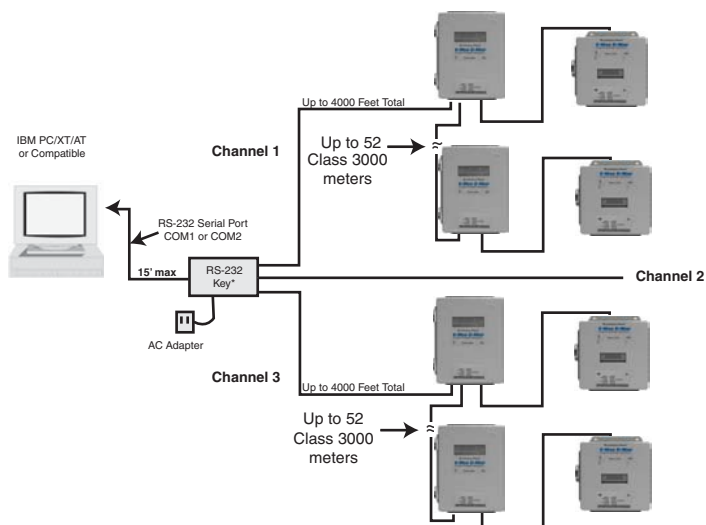

Current Sensor Connections

Current sensor leads can be extended up to 500 feet for remote monitoring. To extend the length of the sensor wires, use #22 AWG twisted-pair with one white and one black wire. The wires should be twisted-pair for best performance.

The easiest way to connect the current sensors is to use the meter's built-in current sensor diagnostics (Chapter 10). To do this, there must be at least 1% of the meter's current rating (amps) flowing in each of the 3 conductors being monitored.

The Class 3000 meter's diagnostic program will ensure that the current sensor installation is done properly.

Current Sensor Connections on the Main Power Board

The current sensor connections are located at the bottom right of the main power board. These three removable blocks are labeled TB1, TB2 and TB3. Each sensor connector has two terminals labeled "Black" and "White". Current sensors should be connected to the meter one at a time and verified using the current sensor diagnostic program.

Connect one of the current sensors to TB1 using the two-screw removable terminal plug. Insert the plug into the terminal for TB1 (Phase A). Wait 5 seconds and look at the meter display.

If the meter displays an error message (see below), remove the plug from TB1 and plug into TB2 (Phase B). If an error message occurs with the sensor plugged into TB2, try again on TB3 until the error message disappears.

The *SENSOR message will disappear when the current sensor is connected to the correct terminal (phase).

- Error Messages:
- *SENSOR A
 - *SENSOR A B
 - *SENSOR A C

Note: A sensor error will also cause the red LED labeled CT ERROR to light up. This LED is located at the top right of the main power board.

Refer to Chapter 10, *Module Diagnostics*, for assistance in troubleshooting these errors.

Chapter 5

Installing the Class 3000 Meter

STEP 1: Install a temporary ground for ESD protection.

Remove the clear plastic shield from the main power board. The shield is held in place by 4 nylon standoffs. Press in the small locktab on the top of each standoff while lifting the shield until it lifts off of the standoff. ***** DO NOT TOUCH INTERNAL CIRCUIT COMPONENTS.*****

STEP 2: Ground the Class 3000 meter enclosure.

The meter's enclosure must be grounded prior to wiring. **FAILURE TO GROUND THE ENCLOSURE CREATES A POSSIBLE SHOCK HAZARD. DO NOT OPERATE THE METER WITHOUT A CHASSIS GROUND TO EARTH.**

Prior to wiring the meter, be sure to discharge any static present on your person.

STEP 3: Wire entry and mounting.

There are three openings on the bottom of the enclosure which are used to bring the power line wires and current sensor leads into the meter. These three openings are for 3/4" conduit.

Mount the Class 3000 meter on the wall surface. The four mounting holes are centered 8.75" H x 4" W.

Note: The Class 3000 meter MUST be mounted indoors, where it will not be affected by the elements.

Bring the voltage and current sensor wires into the enclosure.

Appendix B

RS-232 Communications

Method 1: Modular Plug Method

The easiest method requires using 4 stranded conductors inside a cable that is fitted with an RJ-11 type plug for 4-conductor modular systems at each end of the cable.

*** Do not use any pre-made telephone cables.**

1. Plug the 4-wire RJ-11 cable/plug assembly into Channel A on the RS-232 Key. Connect the other end of this cable to the meter at either of the two RS-485 ports at the top left on the Class 3000 meter main power board.
2. The unused RS-485 port is used to connect another cable to the next Class 3000 meter. This is called a daisy-chain connection, and can be done repeatedly to connect as many as 52 individual Class 3000 meters.
Note: The total combined cable lengths must be no more than 4000 feet.
3. Each meter has two LEDs (yellow and green) located directly below the RS-485 jacks. *If the system is properly wired, these two LEDs will normally be OFF.* These LEDs will flash when the computer and meter are communicating.

Method 2: Terminal Block Method

Class 3000 meters may also be daisy-chained using a 3-conductor cable. Instead of using the two modular jacks for the RS-485 daisy chain, you can use J20 at the bottom right corner of the meter's main power board.

Remove this 3-terminal plug so that you can attach the wires using the screw terminals that are captivated within the plug housing.

1. Daisy-chain the Class 3000 meters by connecting:
 - All HI terminals together
 - All LO terminals together
 - All GND terminals together**** This requires putting two wires into each of the 3 terminals.**
2. Connecting to the RS-232 Key:

You will need to attach an RJ-11 modular plug to the cable that serves the RS-485 system. On each channel on the back of the RS-232 Key, the pin-out for each channel is as follows:

PIN1 - Not used
PIN2 - GND
PIN3 - LO
PIN4 - HI

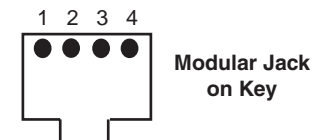

Note: It is okay to use J20 with the modular jacks if needed.

Appendix B RS-232 Communications

A. Hardwired System using the RS-232 Communications Key

(See the hardwired system configuration diagrams following this text.)

The RS-232 Communications Key allows you to connect Class 3000 meters to a personal computer that has the RightEnergy™ software installed. The computer communicates with the meters through the RS-232 Key.

The RS-232 Key must be located within 15 feet of the host computer.

B. Connecting the RS-232 Key to the Computer

The RS-232 Key is supplied with:

- a. (1) 8-conductor cable fitted with RJ-45 plugs
- b. (1) DB-9 serial COM port adapter
- c. (1) AC adapter that converts 120VAC into the 7VAC used to power the RS-232 Key

1. Connect the 8-conductor cable to the left-side jack (labeled "RS232") on the rear panel of the RS-232 Key.
2. Connect the appropriate COM port adapter (DB-9) to the serial port on the back of the computer. Plug the 8-conductor cable from the RS-232 Key into the COM port adapter.
3. Connect the 7VAC AC adapter into the rear panel input on the RS-232 Key. Plug the adapter into a 120VAC outlet. On the front panel of the RS-232 Key, two LEDs will light up (*POWER ON* and *AC ON*).

Note: When the RightEnergy™ software is accessed on the computer, a third LED (*RS232 READY*) will turn on. This indicator will light up as soon as the RightEnergy™ software is booted up and the correct COM port is set up via the settings provided in the software's *Locations* menu.

C. Connecting Class 3000 Meters to the RS-232 Key using RS-485

On the rear panel of the RS-232 Key, there are three jacks labeled as channels A, B and C. These are RS-485 serial communications ports used to connect the meters. Each of these three channels can be connected to as many as 52 individual meters over a total cable distance of 4000 feet. Channels are independent and must not be connected to each other. (See the diagrams following this text.)

Chapter 6 Wiring Diagrams

3-Phase, 4-Wire Installation Diagram

Line Voltage Connections: # 14-22 AWG

Sensor Connections: B = Black Lead
W = White Lead

* Five-amp S.B. inline fuses recommended with voltage rating suited to the service.

** Neutral not used in delta system.

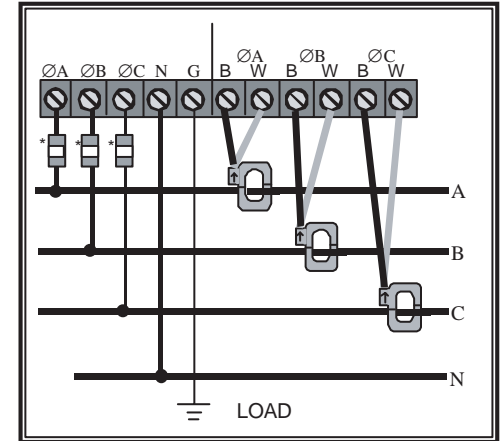

3-Phase, 3-Wire Installation Diagram

Line Voltage Connections: # 14-22 AWG

Sensor Connections: B = Black Lead
W = White Lead

* Five-amp S.B. inline fuses recommended with voltage rating suited to the service.

** Neutral not used in delta system.

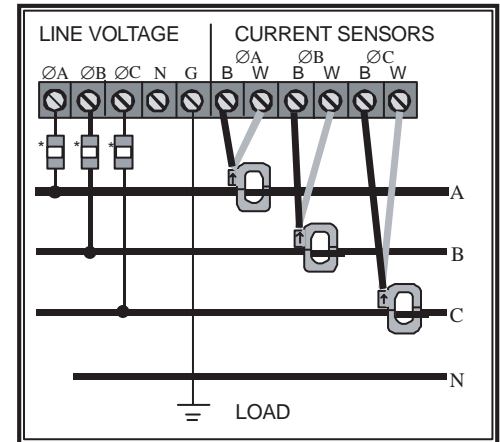

Chapter 7

Monitoring Multiple Loads with One Meter

The E-Mon D-Mon® Class 3000 meter provides extreme flexibility by allowing additional sets of current sensors to be used in parallel so multiple locations can be monitored by one meter. This feature allows a totalized display from two or more loads.

You may use parallel sensors to monitor specific breakers from one panel, specific breakers from more than one panel, two or more complete panels, etc.

When paralleling current sensors, the following rules must be followed for accurate readings.

RULE 1: Current sensors must be installed in complete sets of three, with a maximum of three sets installed in parallel.

RULE 2: All sensors used in parallel must be of the same amperage rating (all 100-amp, all 400-amp, etc.) The rating will be determined by the current rating (amperage) of the meter. A 200-amp meter, for example, must use extra sets of 200-amp current sensors.

RULE 3: All locations being monitored must have the same power source. A 480-volt meter, for example, cannot monitor a 208-volt load, nor can a meter monitor two 480-volt loads if they are from a different originating power source (or from different transformers).

RULE 4: The readings on the display must be multiplied by the number of sets of current sensors installed. Example: Meter readings of 5 kWh with 2 sets of current sensors... $5 \times 2 = 10$ kWh (actual usage).

Note: Sets of current sensors consist of three sensors, one per phase. The multiplier only applies when extra sets of sensors are installed on one meter. **If you are only using one set of three sensors, this multiplier change does not apply.**

Appendix A

RS-485 Communications

Option 1: Internal Modem - An internal modem inside each meter will communicate via the RS-485 network. Simply connect one of the two telephone jacks on the modem to the telephone line to complete the installation.

Note: The modem option has a 9-pin D-connector labeled "RS232". **DO NOT USE THIS CONNECTION.**

Option 2: Local Computer - A local computer somewhere in the building can communicate with the RS-485 network. The computer must be connected to an RS-232 Key. The RS-232 Key is connected to one of the available RS-485 jacks in the meter using an RJ-11 cable.

NOTE: Be sure not to confuse the modem's telephone jacks with the RS-485 jacks!!!

Note: When using one meter with an external modem (Appendix C), only the telephone line is connected. RS-485 is not needed.

Appendix A RS-485 Communications

RS-485 communication allows a computer or modem to communicate with one or more Class 3000 meters. You can connect as many as 64 meters along a 4000-foot RS-485 cable run.

There are two connection methods, daisy-chain and wire terminal, for RS-485 communications.

Daisy Chain Method

This is the simplest method for connecting meters together.



If you are using RJ-11 cable connections (common telephone wire) simply join all meters together so that all the meters are linked together. Each meter has two jacks available for RS-485 to facilitate making a daisy chain. Cables must be assembled so that the plugs are wired pin-to-pin.

Wire Terminal Method (J13 on CPU Board)

1. Connect the HI terminal on J13 of each meter together so that all of the HI terminals on all meters are linked, HI to HI to HI, etc.
2. Connect the LO terminal on J13 of each meter together so that all of the LO terminals on all of the meters are linked, LO to LO to LO, etc.
3. Connect the GND terminal on J13 of each meter together so that all of the GND terminals on all of the meters are linked, GND to GND to GND, etc.

After performing the steps in either of these methods, all of the meters will be connected in a daisy chain. Now you will need to know what device will be used to communicate with this network of meters.

Chapter 7 Monitoring Multiple Loads with One Meter

Monitoring two three-phase loads:

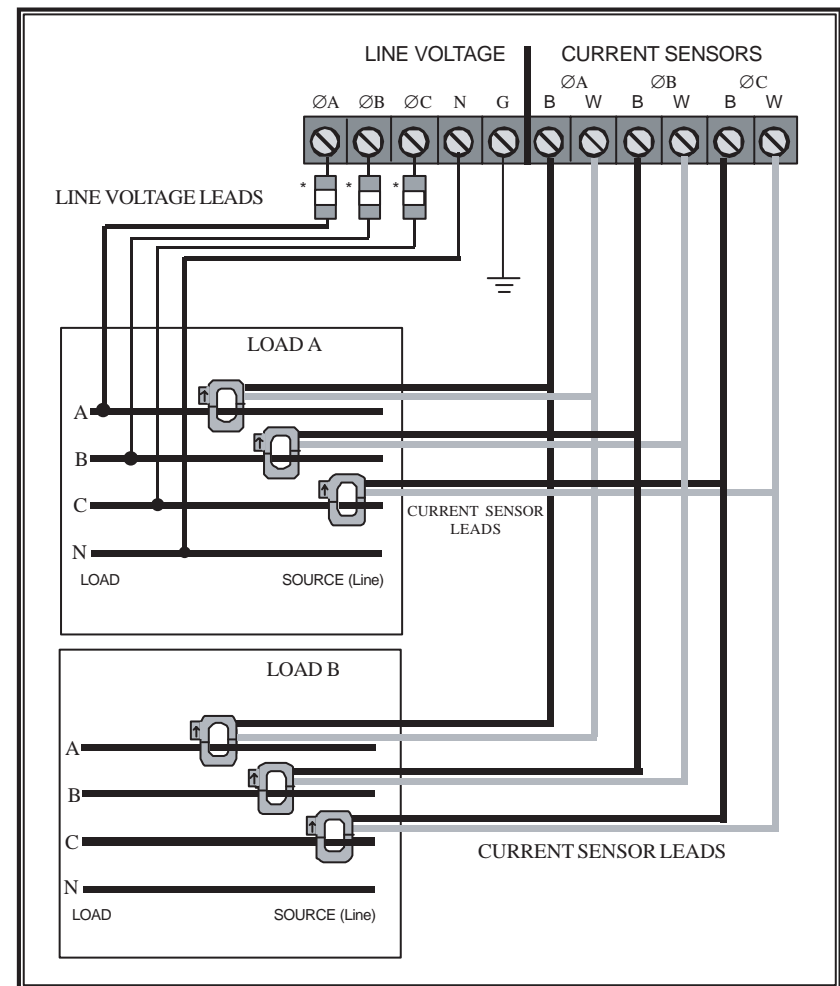

Chapter 8

Reading the Class 3000 Meter Display

The Class 3000 meter features six different displays showing information in 10-second scrolling intervals. Explanations of these displays are as follows:

Screen 1: Total Kilowatt-Hours (kWh)

KILOWATT-HOUR TOTALS	
375.4 kWh	
< >	

Screen 2: Peak Demand (kW) with Date and Time Stamp

KW PEAK:	8.50 kW
ON DATE:	071/01/03
AT TIME:	15:50
< >	

Screen 3: Actual Load (kW) with Present Date and Time

LOAD:	8.50 kW
DATE:	07/04/03
TIME:	12:00:42
< >	

Screen 4: Average Current (amps) Per Phase

PH-A:	4.5 AMPS
PH-B:	4.5 AMPS
PH-C:	4.5 AMPS
< >	

Screen 5: Average Voltage (volts) Per Phase

PH-A:	112.6 VOLTS
PH-B:	112.4 VOLTS
PH-C:	111.7 VOLTS
< >	

Screen 6: Power Factor (PF) Per Phase

PH-A:	100% PF
PH-B:	96.1% PF
PH-C:	98.5% PF
< >	

Chapter 11

Frequently Asked Questions

- Q. When providing line voltage to the Class 3000 meter, can I tap off of the same breaker I am monitoring?**
- A. Yes. The voltage can be pulled from the same breaker being monitored.
- Q. Can the Class 3000 meter's line voltage wires be run in the same conduit as the sensor leads?**
- A. Yes. There will be no effect on the meter if the sensor leads and the line voltage wires are run in the same conduit.
- Q. How do I find the cost for kWh and kW to bill my tenants?**
- A. Your local utility bill should list the cost per kWh and kW; if it does not, simply give your utility a call and ask them the cost per kWh and kW.
- Q. What size wires do I use for the line voltage leads?**
- A. These wires are normally #14 AWG, but be sure to check your local electrical codes for proper sizing.
- Q. What size wire do I use to extend the current sensor leads?**
- A. These wires are normally #14-22 AWG wire. (Consult your electrical codes for proper sizing.)
- Q. The load I need to monitor has parallel feeds. How do I install the sensors for this application?**
- A. There are two ways you can monitor parallel feeds. The first method is to clamp the sensors around all feed wires for each phase. The second way to monitor parallel feeds is to clamp the sensor around one of the feed wires for each phase. When you read the meter, the final reading must be multiplied by the number of feed wires for each phase. For example, if you had 6 conductors in parallel per phase, you would clamp current sensors around one of the conductors of each phase, read the meter and multiply the reading by six (6) to get the total consumption.
- Q. I have two subpanels that I would like to monitor with one Class 3000 meter. These subpanels are fed by different transformers in the building. Can I parallel sensors and monitor both panels with one Class 3000 meter?**
- A. No. These panels cannot be monitored by one Class 3000 meter because they are from different power sources. When you parallel current sensors, all loads being monitored must be from the same voltage source.
- Q. I have 5 breakers in one subpanel I would like to monitor with one Class 3000 meter. Can this be done without having to parallel current sensors?**
- A. Yes. Simply run all the breaker wires through one set of current sensors. Make sure all A-phase circuits are through the A-phase sensor, and the same for phases B and C. The meter should be sized by the highest amount being monitored by one sensor.
- Q. I've gone through the troubleshooting guides, and I still can't get my Class 3000 meter to work. What should I do?**
- A. Contact Hunt Power's technical department toll-free at (866) 944-4868 before removing the meter. Hunt Power's technical department will help you do detailed troubleshooting of the meter installation in the field and will assist you in getting the meter up and running without you having to remove the meter and return it.

Chapter 10 Module Diagnostics

Other Diagnostic Messages

****CHECK METER****

This hardware diagnostic message indicates that something is wrong with the metering circuit. The metering circuit's output is not operating when this message is present on the display. If this message appears, turn off power to the meter, disconnect the current sensor inputs and then momentarily connect a shorting link across each sensor input at TB1, TB2 and TB3. Reconnect the current sensor inputs and power up the meter. If the ****CHECK METER**** message is still present contact Hunt Power at (866) 944-4868.

**** LOW BATTERY ****

This message indicates that the internal backup battery is missing or that the battery needs to be replaced. Contact Hunt Power at (866) 944-4868 for battery replacement information.

***** METER SETUP *****

This message indicates that the meter is not initialized, or that the battery has been removed and replaced. Check the red LED D4 (labeled "CPU ACTIVE"). When the meter is not initialized, this LED will flash twice every one second. Normally, this LED should flash once per second.

If this message appears, try initializing the meter via the RightEnergy™ software. If after initialization the message is still displayed, or if RightEnergy™ software is not available, contact Hunt Power at (866) 944-4868.

***OVERLOAD (ABC)**

This message indicates that the meter has detected an analog overload on one or more current sensor inputs. Overloaded sensor inputs are indicated by phase (A B C).

This message is intended as a diagnostic for current sensor installation to warn of a sensor that is underrated. DURING NORMAL OPERATION AN *OVERLOAD MESSAGE INDICATES THAT THE CONDUCTORS BEING MONITORED ARE AT OR ABOVE 110% OF THE FULL-SCALE CURRENT. This message should not be on continuously. If the cause of the overload cannot be determined or if the current sensors have an incorrect current rating, contact Hunt Power at (866) 944-4868.

Chapter 9 Class 3000 Meter Features

CPU board
push buttons.

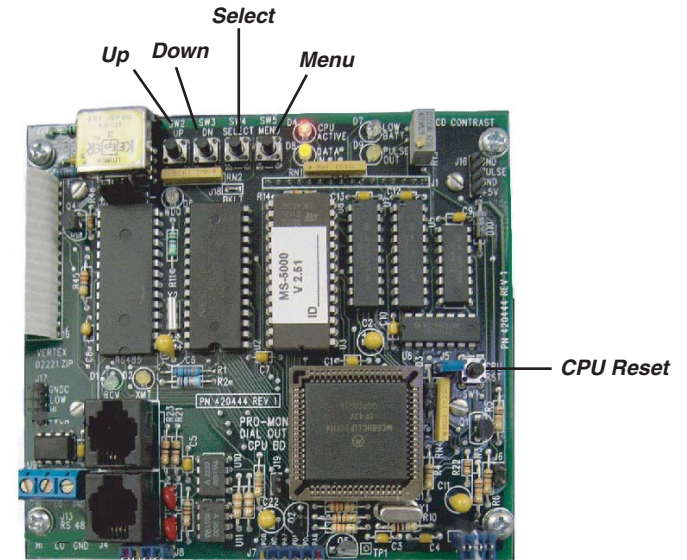

Peak Demand Reset

To reset the recorded peak kW demand, press *Menu*.

On the display, a prompt will be displayed: "Reset kW Demand?"

Press *Select*.

The peak demand (Screen 2) will be reset to zero and the meter will return to its normal scrolling display mode.

Chapter 9 Class 3000 Meter Features

Display Hold Feature

You can "lock" the scrolling display so that it will stay locked on any one of the six screens. On the inside of the door, locate the 4 buttons at the top of the CPU board: *Up*, *Down*, *Select*, and *Menu*. (These buttons are illustrated on the previous page.)

To stop the display from scrolling, follow these instructions:

The *Select* button is used to lock the meter's display so that it stops scrolling and the display remains on one screen.

Use the *Up* and *Down* buttons to choose which of the six screens you would like to display.

Press the *Select* button. At the top of the display, you will see the message HOLD1. This will lock the display for 1 HOUR.

Note: The display hold feature has different selectable time periods.

Pressing *Select* again will show the message HOLD6. This will lock the display for 6 HOURS.

Continuing to press the *Select* button will provide additional timing choices:

HOLD12: Locks the display for 12 HOURS
 HOLD24: Locks the display for 24 HOURS
 HOLD: Locks the display indefinitely

To exit the HOLD mode:

Press the *Select* button as many times as needed until the HOLD message disappears from the display, or simply press the *CPU Reset* pushbutton located near the right center of the CPU board.

** Be sure to exit from the HOLD mode when you are done using this feature.

Chapter 10 Module Diagnostics

Current Sensor Diagnostics (continued)

The table below shows the connection errors in which two or three sensors are connected to the wrong sensor input terminal and at least one sensor is reversed.

Sensor A	Sensor B	Sensor C	Line 4 Display
B	A	<u>C</u>	*SENSOR A B C
B	<u>A</u>	C	*SENSOR B
B	<u>A</u>	C	*SENSOR B C
<u>B</u>	A	C	*SENSOR A
<u>B</u>	A	C	*SENSOR A C
<u>B</u>	A	C	*PH-ANGLE A B
<u>B</u>	A	C	*SENSOR C
A	C	<u>B</u>	*SENSOR C
A	<u>C</u>	B	*SENSOR B
A	<u>C</u>	<u>B</u>	*PH-ANGLE B C
<u>A</u>	C	B	*SENSOR A B C
<u>A</u>	C	<u>B</u>	*SENSOR A C
<u>A</u>	<u>C</u>	B	*SENSOR A B
<u>A</u>	<u>C</u>	<u>B</u>	*SENSOR B
C	B	<u>A</u>	*SENSOR C
C	<u>B</u>	A	*SENSOR A B C
C	<u>B</u>	<u>A</u>	*SENSOR B C
<u>C</u>	B	A	*SENSOR A
<u>C</u>	B	<u>A</u>	*PH-ANGLE A C
<u>C</u>	<u>B</u>	A	*SENSOR A B
<u>C</u>	<u>B</u>	<u>A</u>	*SENSOR B

Chapter 10 Module Diagnostics

Current Sensor Diagnostics (continued)

The table below shows possible sensor connection errors that can be detected and the error message displayed for each. In these conditions, the current sensor wire pairs are tied to the correct inputs, but the direction of at least one sensor is reversed as indicated. These are the most common errors. **NOTE: Underline denotes incorrect installation.**

Sensor A	Sensor B	Sensor C	Line 4 Display
A	B	<u>C</u>	*SENSOR C
A	<u>B</u>	C	*SENSOR B
A	<u>B</u>	<u>C</u>	*SENSOR B C
<u>A</u>	B	C	*SENSOR A
<u>A</u>	B	<u>C</u>	*SENSOR A C
<u>A</u>	<u>B</u>	C	*PH-ANGLE A B
<u>A</u>	<u>B</u>	<u>C</u>	*SENSOR A B C

The table below shows connection errors in which two or three current sensors are connected to the wrong input.

Sensor A	Sensor B	Sensor C	Line 4 Display
B	A	C	*SENSOR A B
A	C	B	*SENSOR B C
C	B	A	*SENSOR A C

Chapter 9 Class 3000 Meter Features

Setting the ID Code

If desired, the meter's ID code can be changed from its factory setting to a different ID code. The ID code is used so that the RightEnergy™ software can distinguish one meter from all others. Each meter must have its own unique ID code when used with the RightEnergy™ software.

STEP 1: Press and hold down the *Menu* button for 9 seconds. Release the *Menu* button when the prompt appears:

Set ID code: 1A

* 1A is a factory default setting. The prompt will display the meter's preset ID code.

STEP 2: The group number will be flashing. Use the *Up* or *Down* button to change the group number by selecting a number from 1 through 8.

STEP 3: Press the *Select* button. The unit letter code will be flashing. Use the *Up* and *Down* buttons to change the letter code (A-Z).

STEP 4: Press *Select*. The meter returns to normal operation.

STEP 5: Verify the new ID code is correct by pressing *SW1*, the *CPU Reset* button located near the right center of the CPU board. The boot-up screen will appear momentarily displaying the ID code on the top line of the display.

Example: DEV: 1A* .05 9600

Note: While in the ID code programming mode, the meter will return to its normal operating mode if there is no button activity after 1 minute.

Chapter 10

Module Diagnostics

Following is a list of diagnostic messages that may appear on the meter display. DIAGNOSTIC MESSAGES SHOULD NOT BE ON CONTINUOUSLY WHEN THE METER IS INSTALLED PROPERLY AND IS IN WORKING ORDER.

Line Voltage Diagnostics

The diagnostics program detects line voltage faults by displaying one of two messages:

***PHASE [2]** or ***PHASE [3]**

***PHASE [2]**

Indicates that the 3-phase line voltage is not hooked up in the proper phase sequence. This message should never be seen on the display continuously. The meter will not display correct electrical data in this condition. The phase sequence problem must be remedied in order for the meter to work properly.

***PHASE [3]**

Indicates that line voltage is missing on Phase B and/or Phase C. This message will appear whenever the power on either Phase B or Phase C is off. Screen 5 (*Voltage per Phase*) will also indicate a loss of line voltage.

Current Sensor Diagnostics

The load current must be at least 1% of the meter's rated load in order to operate.

Current sensor diagnostics can detect:

1. Reversed current sensors
2. Incorrect phase correspondence
3. Unusually low power factor (0.642 or lower)

Two different sensor diagnostic messages are used:

***SENSOR** or ***PH-ANGLE**

***SENSOR (ABC)**

Used to detect reverse phasing of a current sensor. This message should never be seen in normal operation of a properly installed meter. See Chapter 2, *Current Sensor Assembly*, or Chapter 4, *Meter Terminal Block Connections*.

Chapter 10

Module Diagnostics

Current Sensor Diagnostics (continued)

***PH-ANGLE (ABC)**

Used to detect the swapping of current sensor phases. This message could (in some rare cases) indicate an extremely low power factor condition. This message may appear intermittently due to changes in line conditions. It should never be on continuously. See Chapter 2, *Current Sensor Assembly*.

Note: If you have connected the current sensor to all three terminals and the error message is still appearing, reverse the black and white wires and repeat the previous steps until the correct connection is found.

If the ***SENSOR** error message disappears you have found the correct sensor connection; however, the current sensor was not installed properly around the conductor, or the sensor wires were extended and not spliced together correctly. Correct the sensor installation, reconnect the black wire to the black terminal and the white wire to the white terminal on the plug and reinstall the plug into the correct phase terminal for that current sensor. The error message should disappear and the current sensor is now installed properly.

If the ***SENSOR** message does not appear at any time while trying all 3 inputs both ways, check the AC voltage output from the current sensor between the black and white wires using an AC voltmeter. It will read approximately zero volts indicating that the load current is very small (or zero) or the current sensors are not secured properly (tight connection between core halves or lead splices not secure).

Once the first current sensor is connected properly and the error message disappears, repeat the previous procedure for the remaining two current sensors. When all error messages have disappeared and all sensors are installed correctly, the meter is operational.